

UNSLOTTED INDENTED HEX HEAD TYPE "A" SMS

XXXXUHAZ
APRIL, 2014
REV 00
PAGE 1 of 1

Nominal Screw Length	Tolerance On Screw Length
Up To & Including 1"	± .030
Over 1"	± .050

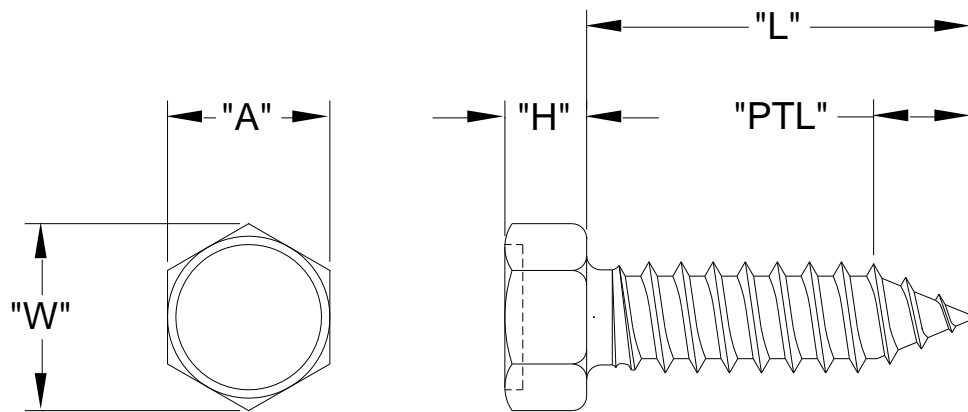

Nominal Screw Size	"D"		"d"		"PTL"	"A"		"W"	"H"	
	Major Diameter		Minor Diameter		Point Taper Length	Width Across Flats		Width Across Corners	Head Height	
	Max.	Min.	Max.	Min.	Ref.	Max.	Min.	Min.	Max.	Min.
#6-18	0.141	0.136	0.102	0.096	0.196	0.250	0.244	0.272	0.093	0.080
#10-12	0.194	0.188	0.133	0.126	0.266	0.312	0.305	0.340	0.120	0.105
#14-10	0.254	0.248	0.185	0.178	0.354	0.375	0.367	0.409	0.190	0.172
#20-9	0.333	0.327	0.234	0.226	0.433	0.500	0.489	0.545	0.230	0.208
#24-9	0.390	0.383	0.291	0.282	0.511	0.562	0.551	0.614	0.295	0.270

<p>Standard: ASME B18.6.3 Material: Carbon Steel, Heat Treat: Case Hardened Finish: Commercial Zinc, Bake & ROHS Compliant Clear Chromate Per ASTM F1941 Code Fe/Zn 3A</p>	<p>Common Uses: Used In Combination With Over-The-Thread Washers; Used In Soft Plastics, Soft Woods, Thin Sheet Metal(<60% Of Major Dia.), Aluminum Extrusions</p>
--	--