

# TYPE 1 CROSS RECESS 82° OVAL HEAD MACHINE SCREW

XXXXPOMZ
APRIL, 2014
REV 00
PAGE 1 of 1

Nominal Screw Size	#0 Thru #12	1/4 Thru 3/4
Nominal Screw Length	Tolerance	
Up To & Including 1/2"	-0.02	-0.03
Over 1/2 To 1", Inclusive	-0.03	-0.03
Over 1" to 2", Inclusive	-0.06	-0.06
Over 2"	-0.09	-0.09

**NOTE:**  
 Length Tolerance Is Applied To "Lo"  
 "Lo" = "L" + "C"  
 Whereas"  
 "L" = Screw Length Ordered  
 "C" = Crown Height

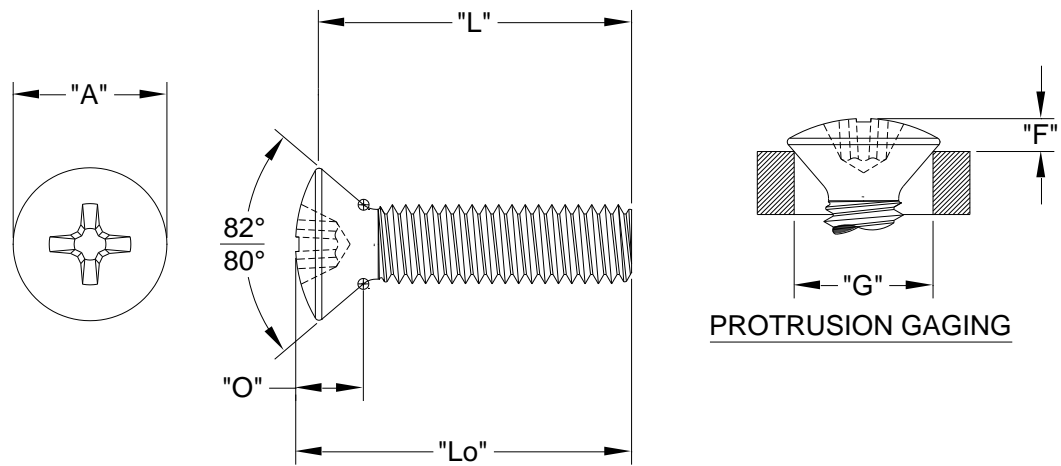

Nominal Screw Size	Basic Screw Size	Major Diameter		These Lengths or Shorter Are Undercut	"A"		"O"	Driver Size	Recess Penetration Gaging Depth		"G"	"F"	
		Max.	Min.		Head Diameter		Total Head Height		Max.	Min.	Gaging Diameter	Protrusion Height	
					Max.	Min.	Ref.					Max.	Min.
#4 - 40	0.112	0.1120	0.1061	3/16	0.212	0.191	0.104	1	0.087	0.070	0.172	0.069	0.048
#6 - 32	0.138	0.1380	0.1312	3/16	0.262	0.238	0.128	2	0.094	0.069	0.220	0.080	0.057
#8 - 32	0.164	0.1640	0.1571	1/4	0.312	0.285	0.152	2	0.108	0.084	0.267	0.091	0.066
#10 - 24	0.190	0.1900	0.1818	5/16	0.362	0.333	0.176	2	0.126	0.102	0.313	0.102	0.075
#10 - 32		0.1900	0.1831										
1/4 - 20	0.250	0.2500	0.2408	7/16	0.477	0.442	0.232	3	0.156	0.131	0.424	0.129	0.095
5/16 - 18	0.313	0.3125	0.3026	1/2	0.597	0.556	0.290	4	0.218	0.194	0.539	0.155	0.117

Standard: ASME B18.6.3 Material: Carbon Steel, 60,000 psi Minimum Tensile Stress Finish: Commercial Zinc & ROHS Compliant Clear Chromate Per ASTM F1941 Code Fe/Zn 3A	Common Uses: Nuts, Tapped Holes, Threaded Inserts More decorative finish than a Flat Head; Nests in countersunk applications; Good centering potential
--	--